



## DuraShiner® CFBR

The DuraShiner® CFBR from Belanger is the only automatic tire shiner specifically designed for in-bay wash applications. It's built to work for in-bay operators, delivering both immediate new revenue, and sustainable repeat business. The DuraShiner CFBR overcomes even extreme vehicle orientation issues, with Floating Head Technology™ that auto-aligns the applicator brush, "bringing the shine to the tire" every time.

Competitors' so-called 'in-bay' tire shiners force customers between two fixed guide rails, rendering it impossible for the shiner to adjust to the various vehicle angles encountered in a drive-through wash bay. The DuraShiner CFBR is different. Instead of using guiderails, the DuraShiner CFBR adapts to the customers' driving habits, providing superior results to competitors' fixed-position in-bay tire shiners.

The DuraShiner CFBR brush fill is designed for longer wear and less tear. The soft-tipped nylon brush easily conforms and accommodates all tire sizes, including the most rugged truck tires, to deliver the perfect shine every time. We now even offer the optional 108" brush length for complete tire shine coverage, even on today's largest truck tires.

With the Insta-Chem controls you will also save on chemical consumption and costs. The operator programmable Insta-Chem controls allow you to deliver chemical "on demand" to the tire shine brush as the vehicle is approaching for on-time application and complete wheel coverage with every wash. With no chemical waste between tire shine services your profit stays where it belongs — in your pocket!

## FEATURES & BENEFITS

### Floating Head Technology™

Uses articulating bi-knuckle arms, "bringing the shine to the tire"™

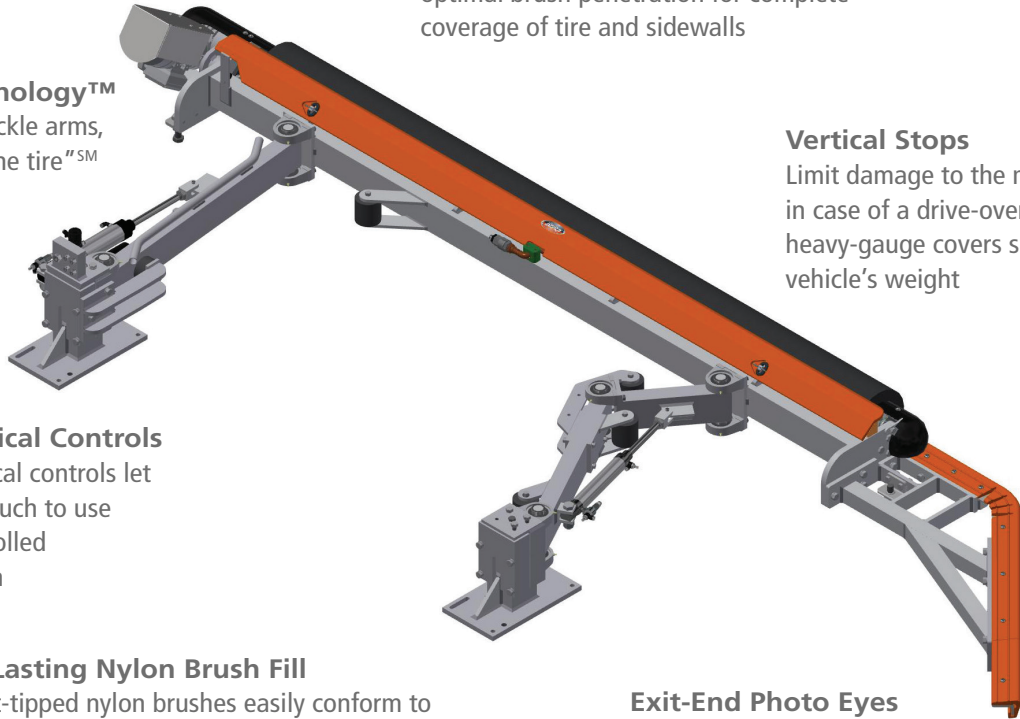

### Extended Pressure Adjustment

Adjustable pressure feature to ensure optimal brush penetration for complete coverage of tire and sidewalls

### Vertical Stops

Limit damage to the machine in case of a drive-over, while heavy-gauge covers support the vehicle's weight

### insta-Chem Chemical Controls

Programmable chemical controls let you determine how much to use for on-time and controlled chemical consumption

### Long Lasting Nylon Brush Fill

The soft-tipped nylon brushes easily conform to all tire sizes, including the most rugged truck tires on the road today, to deliver the perfect shine every time. Available in 8' or 9' brush length

### Exit-End Photo Eyes

Retract machine quickly to help prevent damage in case of accidental customer back-up

## REQUIREMENTS

### Physical Examples

	8'	9'
Component Height	1'	1'
Minimum Bay Width Required	14'	14'
Minimum Bay Length Required	16' 6"	17' 6"

### Utility Examples

Electrical (1) 120 VAC constraint from Controller  
(1) Exit Function 120 VAC from Controller or optional signal from POS

Pneumatic 1/4" airline @ 90 PSI minimum, 120 PSI maximum

### Belanger

31840 Enterprise Drive, Bldg 5  
Livonia, MI 48150 USA  
[belangerinc.com](http://belangerinc.com) | 248-349-7010